

Installation Guide

For

Essae Tank weighing system(TWS) Load cell kit

Capacity: Up to 10t

PREPARED BY	CHECKED BY	APPROVED BY	PAGE NO	DOCUMENT NO
Refer digitally approved sign in page 21 of 21			1 of 21	IGP-001-TW R02

Parts supplied for Tank weighing system (TWS)

Load cell kit

Shear Beam Load cell kit

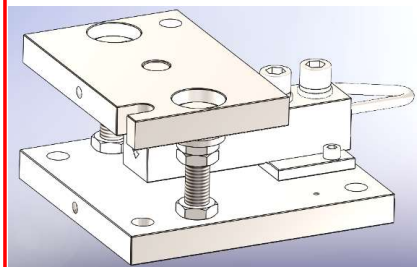

Standard Indicator Models

DX-451



or

SI-850



or

DI-60



**Indicators with
Flame proof enclosure**



or



Junction Box

SS Box

or

Flame proof box

PREPARED BY	CHECKED BY	APPROVED BY	PAGE NO	DOCUMENT NO
Refer digitally approved sign in page 21 of 21			2 of 21	IGP-001-TW R02

Load cell kit Design

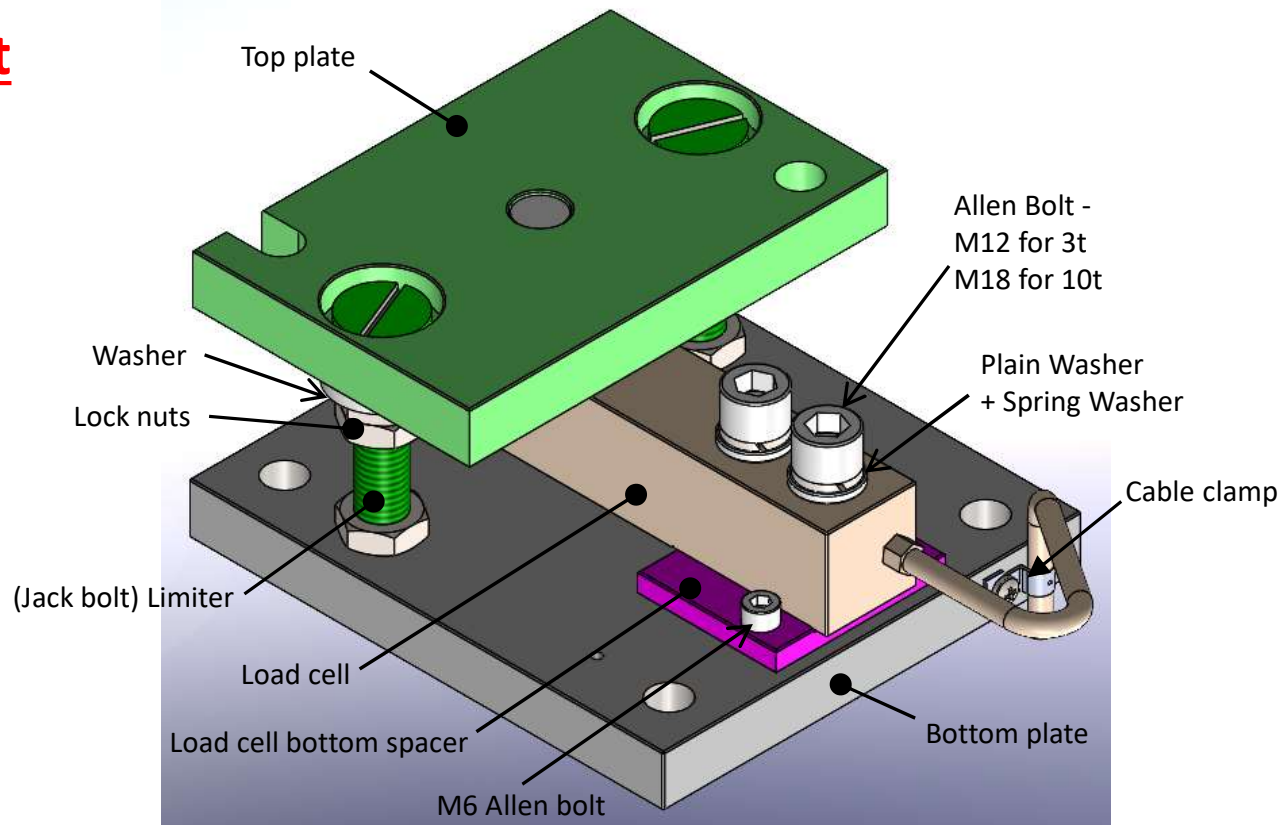

PREPARED BY	CHECKED BY	APPROVED BY	PAGE NO	DOCUMENT NO
Refer digitally approved sign in page 21 of 21			3 of 21	IGP-001-TW R02

General Arrangement(GA) drawing

All dimensions are in mm

Up to 3t

6t to 10t

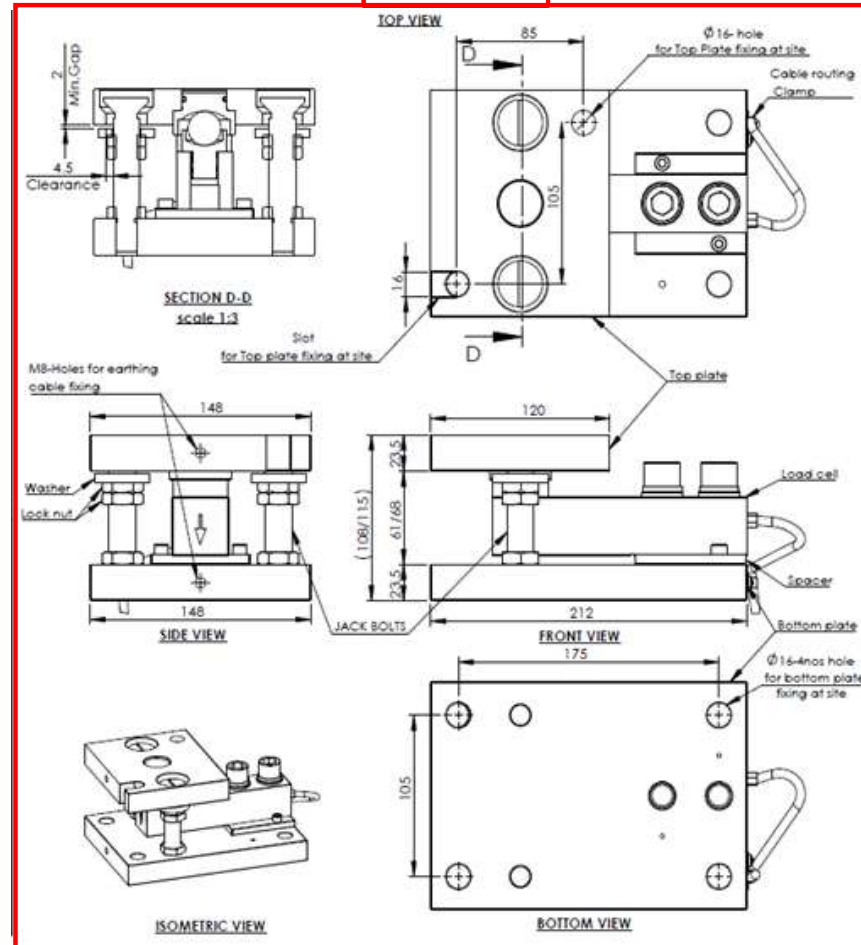
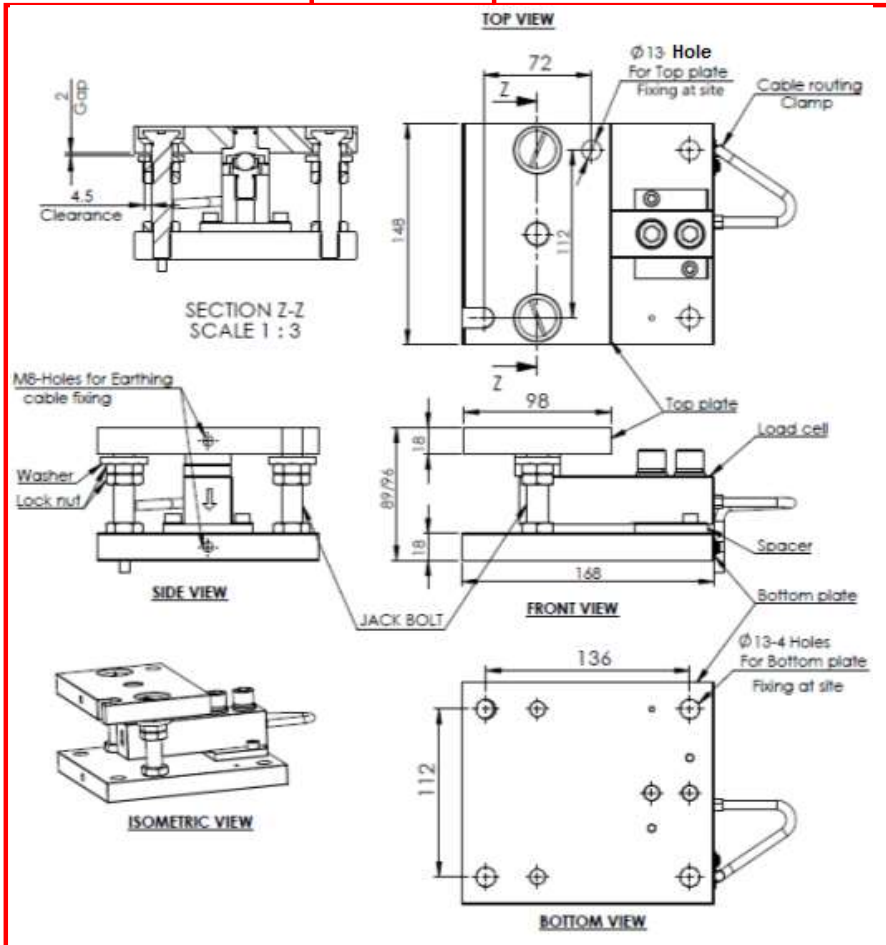

PREPARED BY

CHECKED BY

APPROVED BY

PAGE NO

DOCUMENT NO

Refer digitally approved sign in page 21 of 21

4 of 21

IGP-001-TW R02

Different types of Tanks and their mounting positions

Bottom mounted Tanks



Side Pillars mounted Tanks

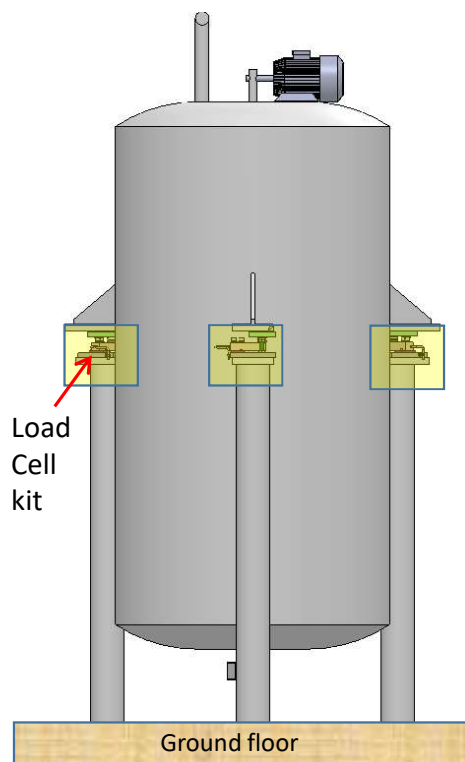

Side Mezzanine floor mounted

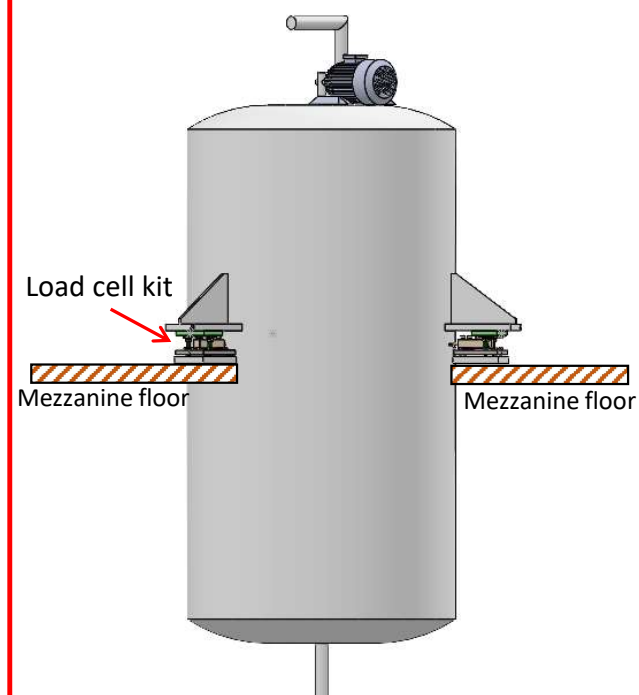

PREPARED BY	CHECKED BY	APPROVED BY	PAGE NO	DOCUMENT NO
Refer digitally approved sign in page 21 of 21			5 of 21	IGP-001-TW R02

Load cell mounting directions for different types of tanks

Top view with Load cell mounting directions

Bottom mounted Tanks

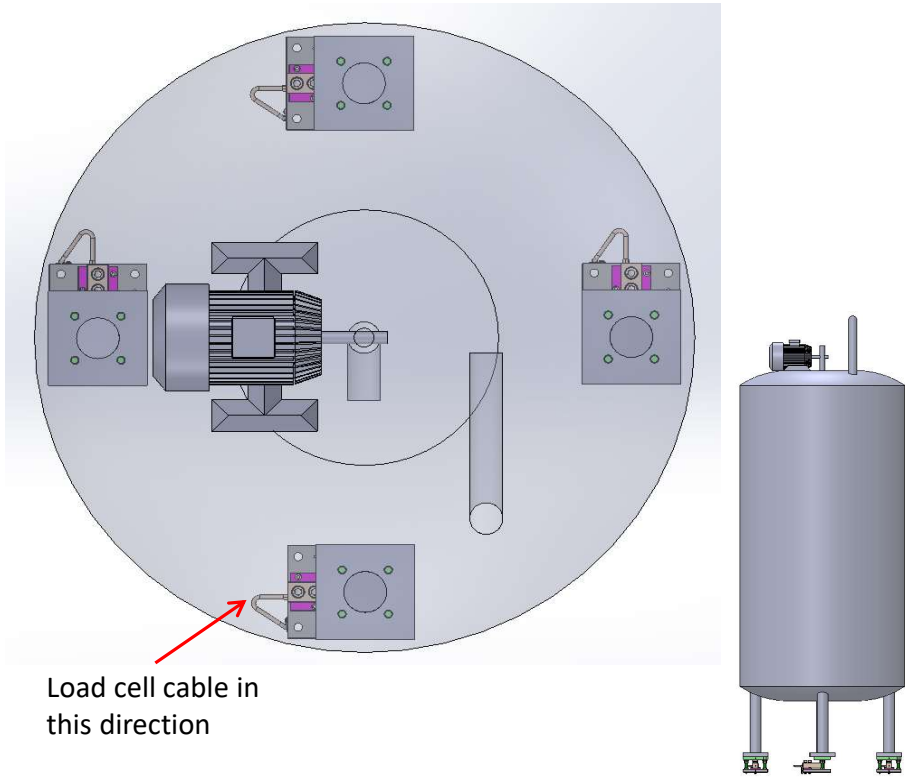

Side and Mezzanine floor mounted

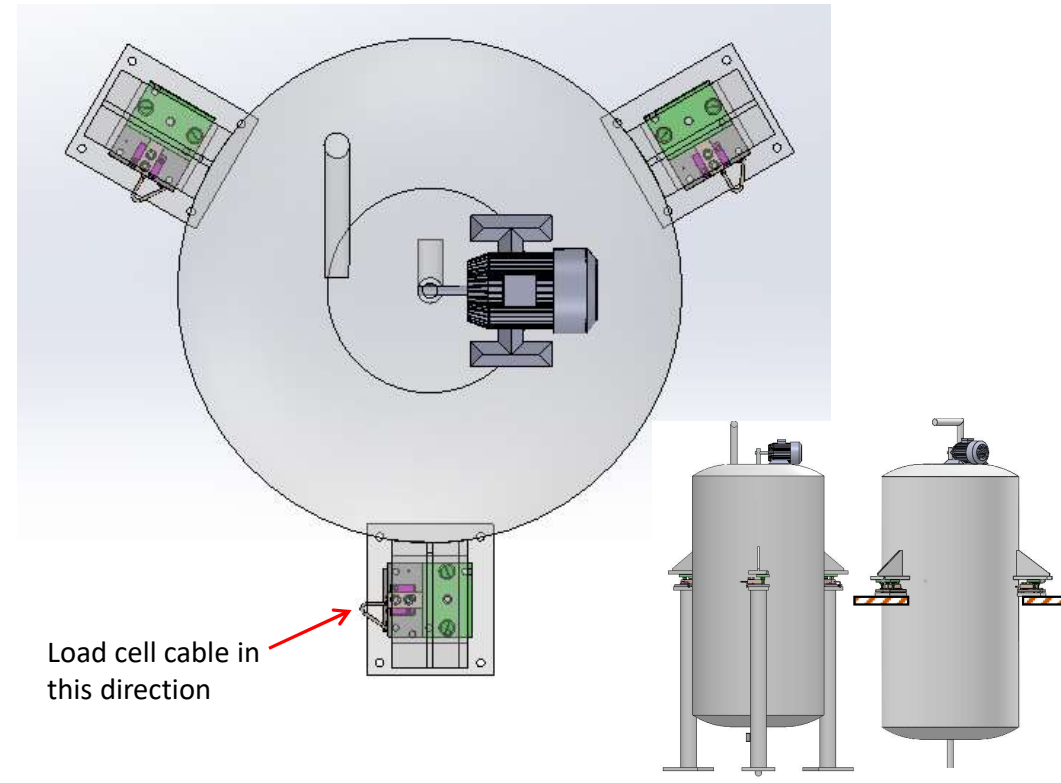

PREPARED BY

CHECKED BY

APPROVED BY

PAGE NO

DOCUMENT NO

Refer digitally approved sign in page 21 of 21

6 of 21

IGP-001-TW R02

General Note

Customer's scope:

1. All Mechanical fabrication work, Skilled and Un-skilled labor for installation.
2. Modification of the existing supports of the Tank to match new Load cell kit plates.
3. Screw jack / Hoist / Crane required for lifting the tank.
4. At the time of welding and fabrication, load cell can be removed from the kit (If required).
5. Temperature of fabrication structure coming in contact with load cell kit, should be less than 45° C degree
6. Any additional cables and cable routing.
7. Shim materials used to keep below load cell kits for levelling. (If required, shims can be purchased separately from **Essae** along with load cell kits)
8. Tank legs should be with mounting plates. If any additional Top plate and Bottom plates are required, suitable plates can be separately purchased along with TWS kit from Essae.
9. No vibration is allowed to the tank while taking weight reading. If vibrations are present, anti-vibration pads should be used between tank legs & TWS kit. (Suitable anti-vibration pads can be purchased as option from **Essae** along with load cell kits)
10. Clamping bolts & Tools required as per Page-21
11. Arrangement of Standard weights required for calibration
(**Essae** team to inform Customer about Standard weight details depending on capacity of Tank weighing system)

Installation & User conditions:

1. At the time of fabrication/welding of structures during installation, load cell kit should be away from welding area to avoid damage.
2. All Inlet and outlet rigid pipes should be with flexible hoses to avoid weighing errors.
3. The Stirrer of tank, if used, should be stopped and weight reading should be taken under stable condition.
4. Load cell cables should not cross or go along with AC lines.

PREPARED BY	CHECKED BY	APPROVED BY	PAGE NO	DOCUMENT NO
Refer digitally approved sign in page 21 of 21			7 of 21	IGP-001-TW R02

DOs & DONTs during installation

Sl. No.	Activity	DONTs	DOs
1	During Plates welding	No Load cell in the kit	Remove Load cell from the kit
2	Jack bolts lock nut	No loosening until tank is fixed on Load cell kit	Loosen after tank is fixed on Load cell kit
3	All inlet & Outlet pipes	Should not be rigid	Should be with flexible hoses
4	Vibration on tank	No vibration	Use anti-vibration pads *
5	Weight data reading	No stirring ON	After stopping of stirrer & tank is stable
6	Load cell cables	No crossing or along with AC lines	Should be routed away from AC lines

* Refer page-7 of Customer scope note no. 9

PREPARED BY	CHECKED BY	APPROVED BY	PAGE NO	DOCUMENT NO
Refer digitally approved sign in page 21 of 21			8 of 21	IGP-001-TW R02

Installation sequence

STEP-1

* Inspect received kit & ensure there is no gap between Top Plate & Washer as shown (means Jack bolt is in locked condition)

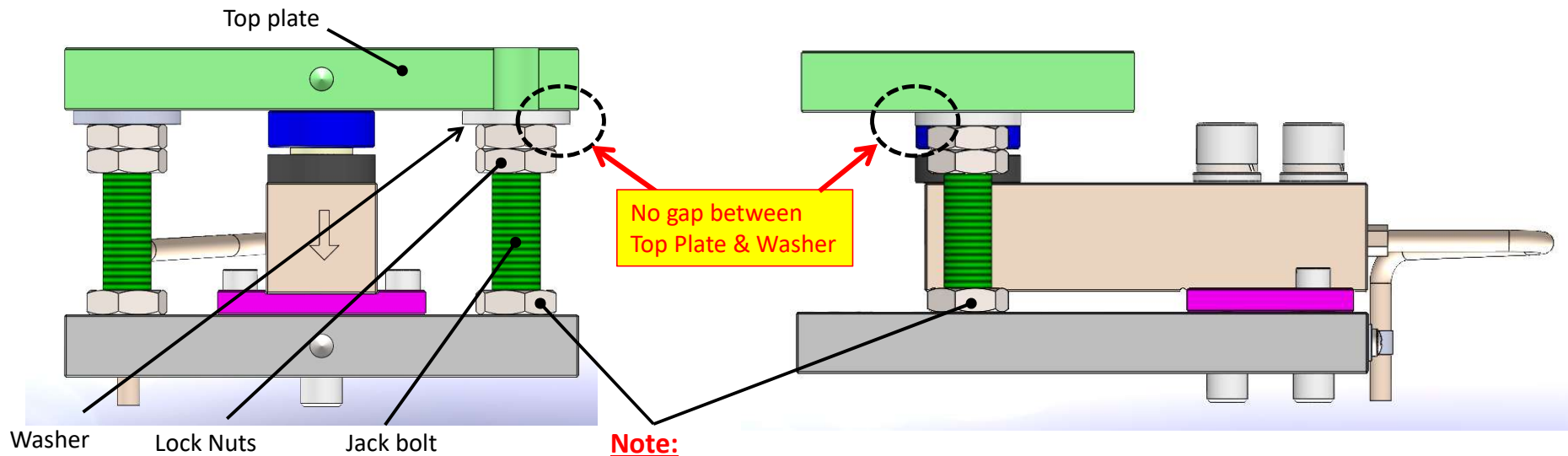

Note:

Do not loosen these Nuts at any point of time

PREPARED BY	CHECKED BY	APPROVED BY	PAGE NO	DOCUMENT NO
Refer digitally approved sign in page 21 of 21			9 of 21	IGP-001-TW R02

STEP-2

* Check and ensure all surfaces of Load cell kit mounting places are level using Spirit bubble leveler

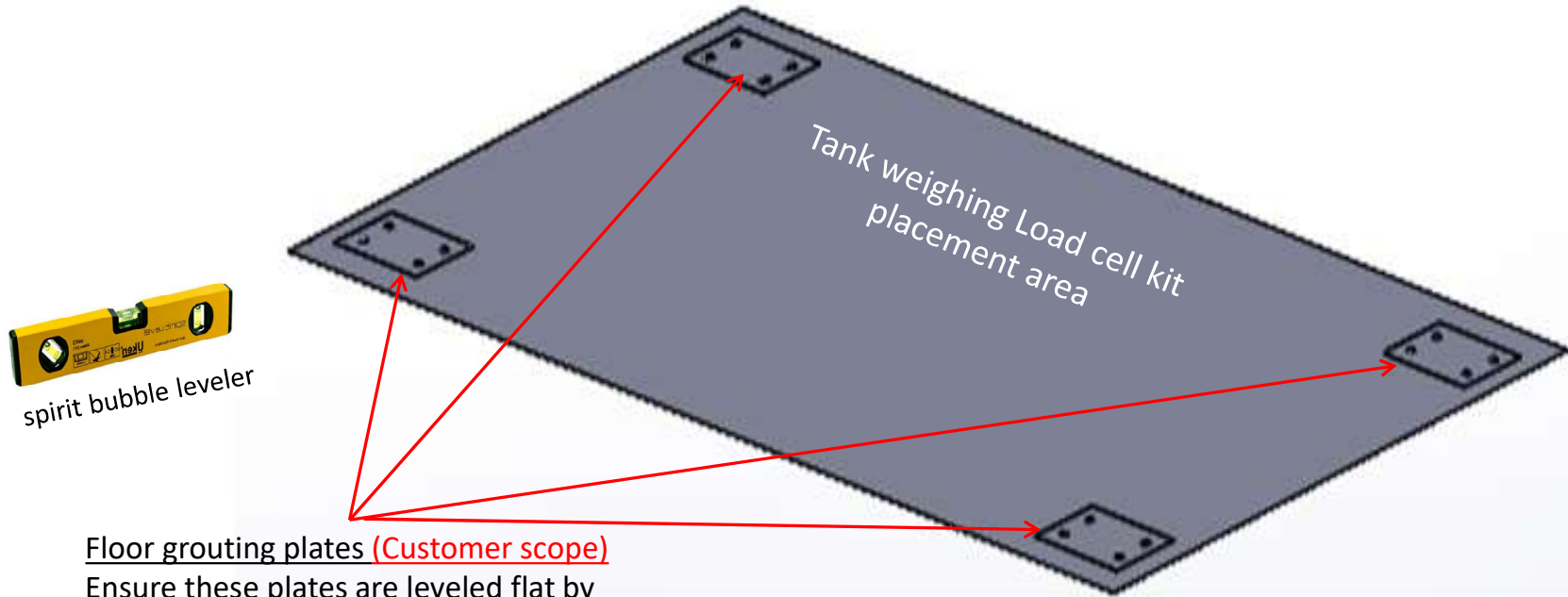

spirit bubble leveler

Floor grouting plates (Customer scope)
Ensure these plates are leveled flat by checking with spirit bubble leveler

PREPARED BY	CHECKED BY	APPROVED BY	PAGE NO	DOCUMENT NO
Refer digitally approved sign in page 21 of 21			10 of 21	IGP-001-TW R02

STEP-3 * Level checking of Tank Legs

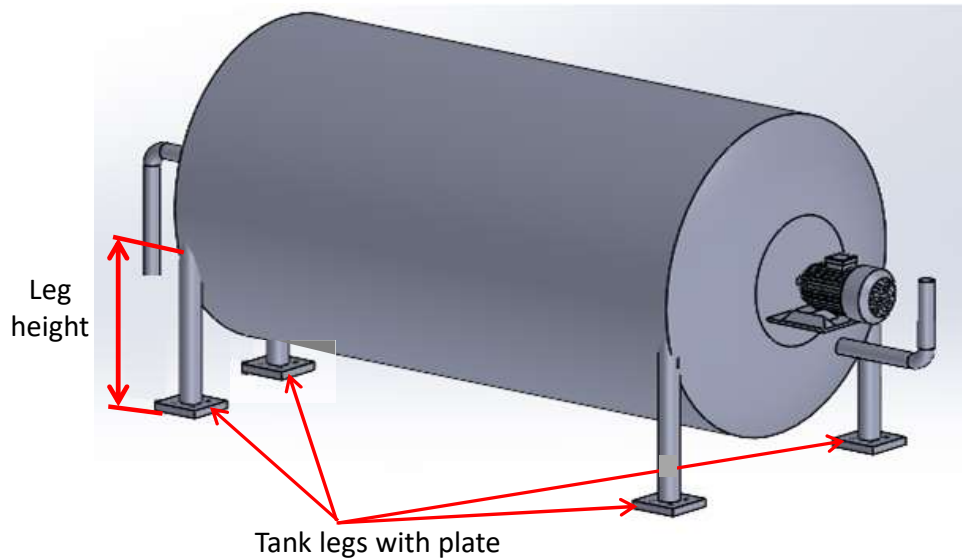

- 1) Ensure all these legs heights are within 1-2mm tolerance.
- 2) Ensure bottom surfaces of all these Leg plates are horizontally flat and in same level

PREPARED BY	CHECKED BY	APPROVED BY	PAGE NO	DOCUMENT NO
Refer digitally approved sign in page 21 of 21			11 of 21	IGP-001-TW R02

STEP-4 Removing of Load cells from Essae Tank weighing kit, if Kit top plate to be welded to tank legs

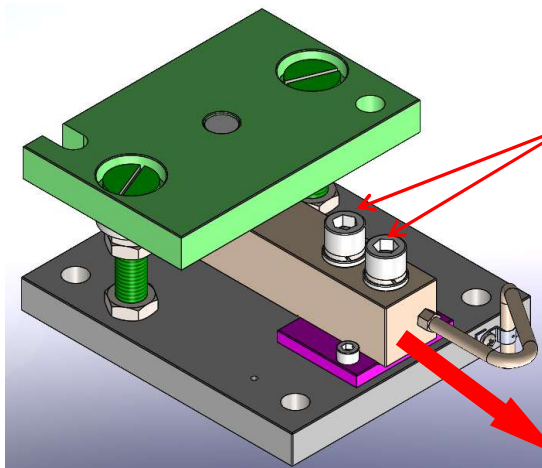

1. Un-screw & remove these 2nos Allen bolts using Allen key-B (for Allen key size, refer page-21)

2. Remove the load cell with ball in this direction

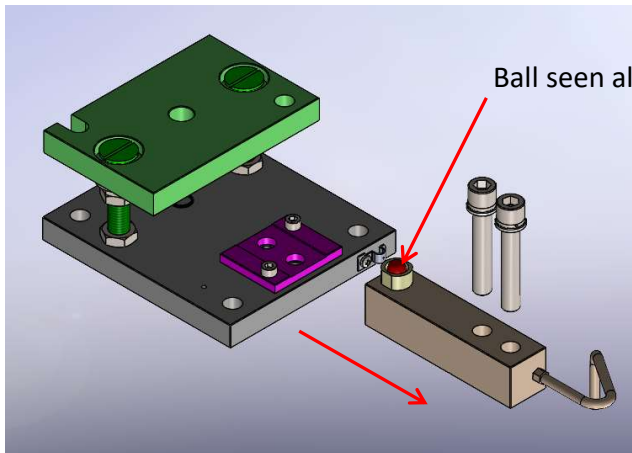

Ball seen along with load cell

Assy condition after removing Allen Bolts & Load cell-with-Ball

PREPARED BY	CHECKED BY	APPROVED BY	PAGE NO	DOCUMENT NO
Refer digitally approved sign in page 21 of 21			12 of 21	IGP-001-TW R02

STEP-5

- * Position all Load cell kits on planned mounting locations/floor as shown.
- * Ensure all the heights of Load cell kits 1, 2, 3 & 4 are at same HEIGHT with water tube leveler

Note:

Before starting this step-4, below steps – 2 & 3 should be completed. i.e.,

Step-2

Check and ensure all surfaces of Load cell kit mounting places are level using Spirit bubble leveler.

Step-3

Level checking of Tank Leg with plates

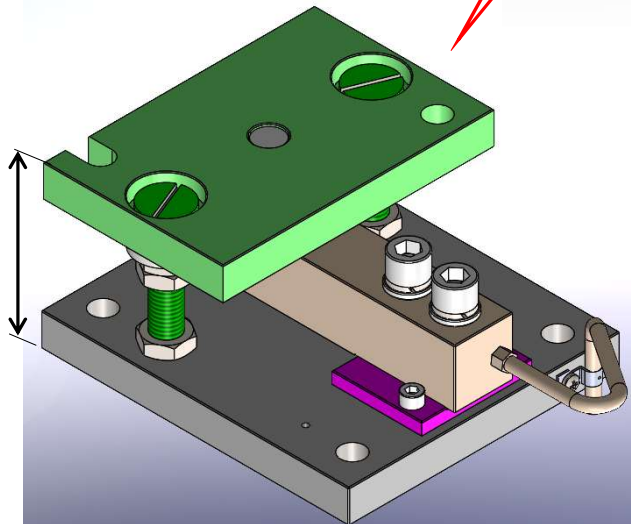
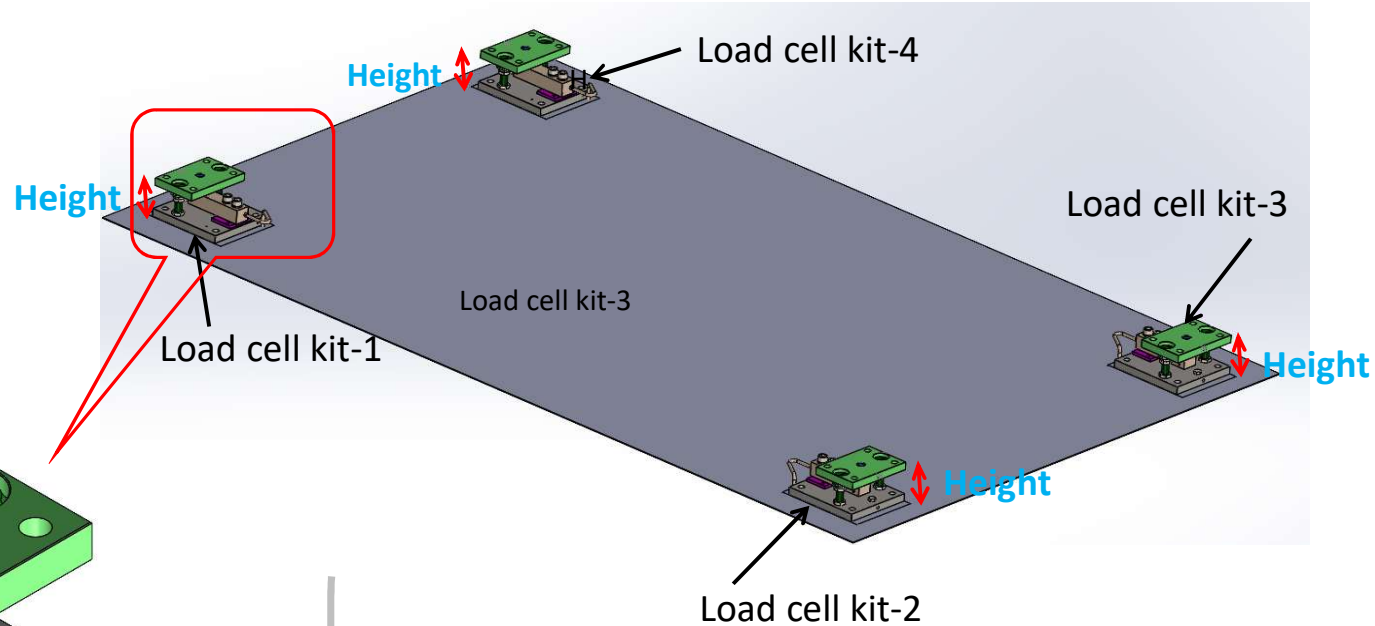

Height

(in locked condition)
115mm – for 10t
113mm – for 3t

Use water tube leveler to ensure same height

PREPARED BY	CHECKED BY	APPROVED BY	PAGE NO	DOCUMENT NO
Refer digitally approved sign in page 21 of 21			13 of 21	IGP-001-TW R02

STEP-6

- * Position the tank on all Load cell kits as shown in below picture.
- * Clamp Load cell kit top plates to Tank leg plates.

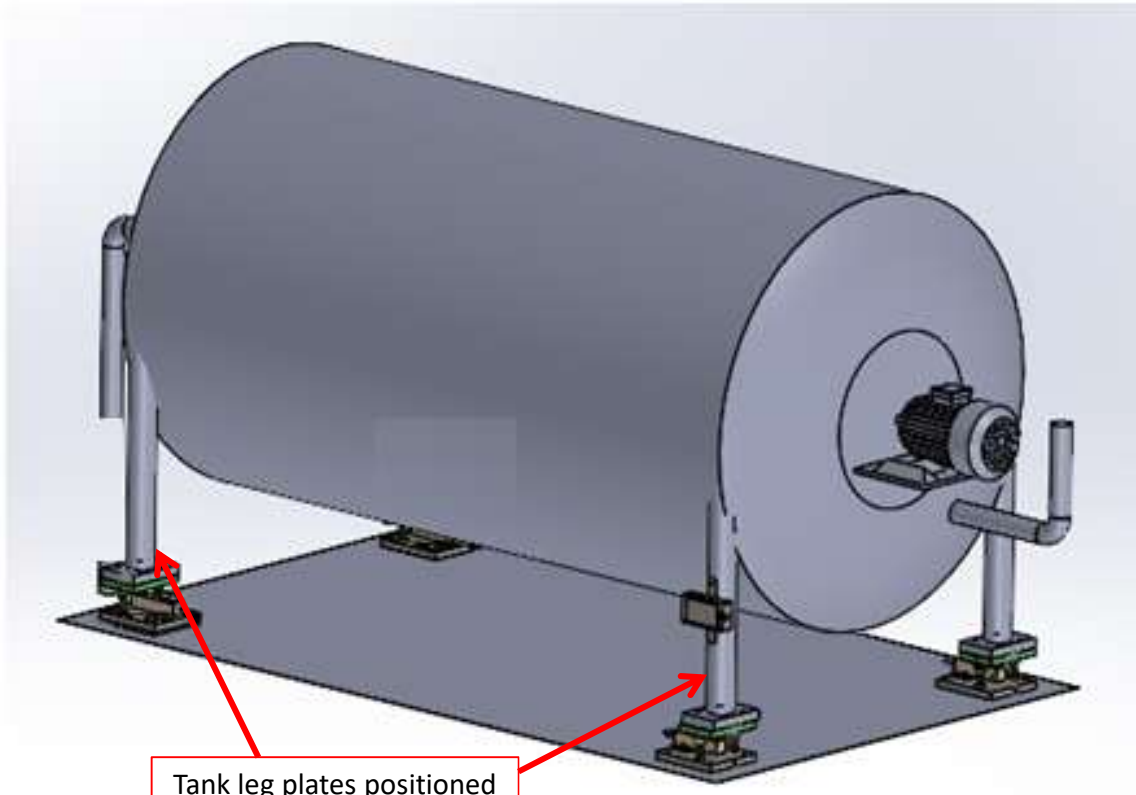

Tank leg plates positioned on all Load cell kits

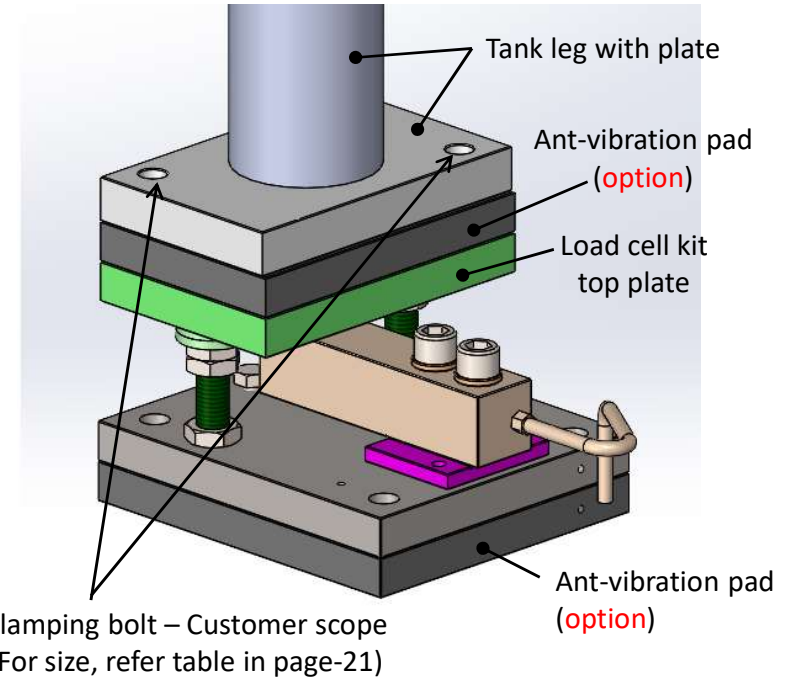

Enlarged view of Tank leg plate positioning

PREPARED BY	CHECKED BY	APPROVED BY	PAGE NO	DOCUMENT NO
Refer digitally approved sign in page 21 of 21			14 of 21	IGP-001-TW R02

STEP-7 Load cell cable clamping direction

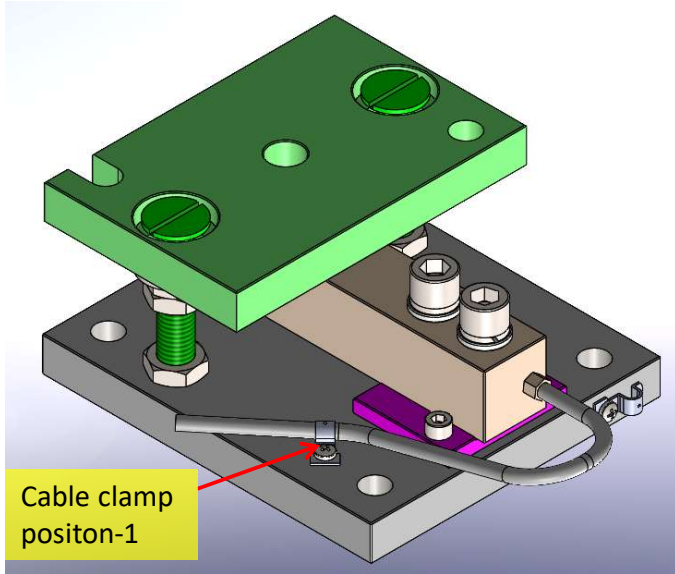

Option - 1

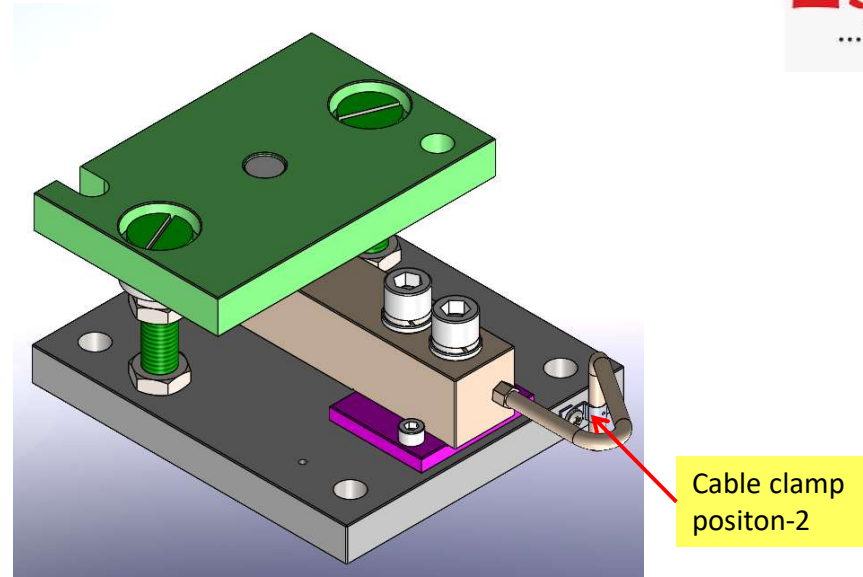

Option - 2

Note: Any one above option can be used depending on site conditions

PREPARED BY	CHECKED BY	APPROVED BY	PAGE NO	DOCUMENT NO
Refer digitally approved sign in page 21 of 21			15 of 21	IGP-001-TW R02

STEP-8 Unlocking sequence of limiters for calibration of load cell kits

- 1) Connect the display indicator to the load cell kits through junction box.
- 2) Slowly unlock the lock nuts till the reading in indicator is stable.
- 3) Tare the indicator reading.
- 4) Fill the tank with known quantity of required liquid. This is Weight-A
- 5) Unlock the lock nuts till the indicator reading is stable.
- 6) Place standard weight (Weight-B) on available place on tank.
- 7) Repeat above step-5.
- 8) Calibrate the system to show total weight of (A+B)
- 9) Fill the tank till the indicator reading shows full load capacity.
- 10) Repeat above step-5.
- 11) Rotate the lock nuts in anti-clockwise direction to create gap of 2mm.

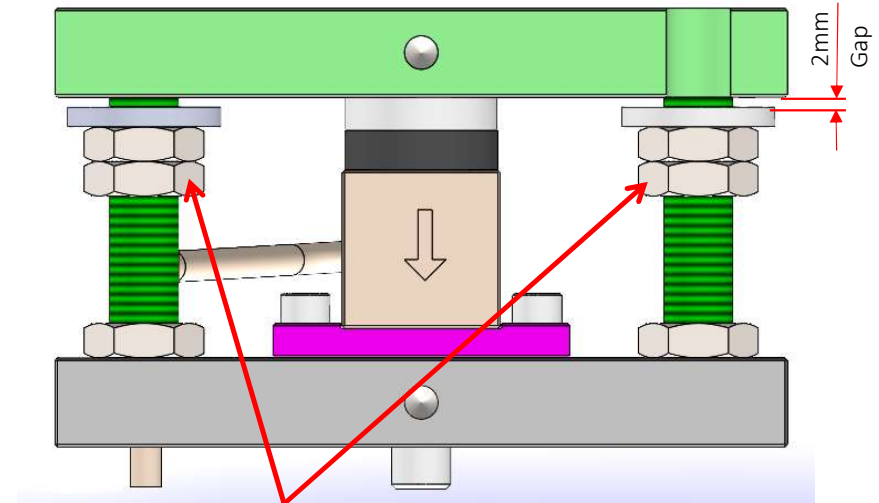

Lock nuts



Use Spanner-B for loosening or tightening
(for spanner size, refer table in page 21 of 21)

STEP-9 TWS Performance Verification:

- 1) Check for Zero Return after loading and Unloading.
- 2) Conduct Repeatability test
- 3) Enable Power Retain function and check for working.

This completes the installation

PREPARED BY	CHECKED BY	APPROVED BY	PAGE NO	DOCUMENT NO
Refer digitally approved sign in page 21 of 21			16 of 21	IGP-001-TW R02

Load cell kit assy outside details – for understanding

Locked condition:
No gap between Top Plate & Washer

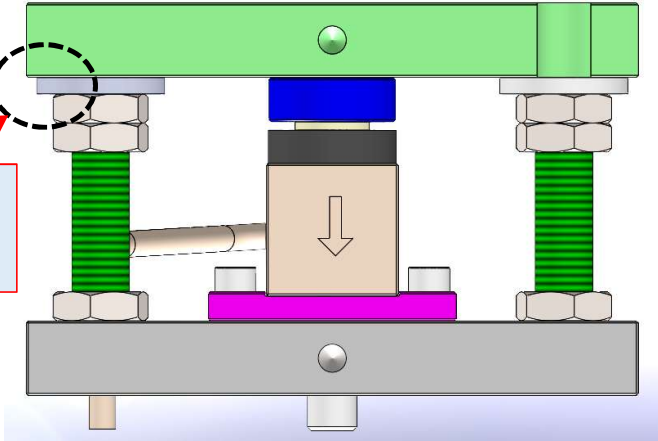

Kit with locked condition

Un-locked condition:
Gap between Top Plate & Washer

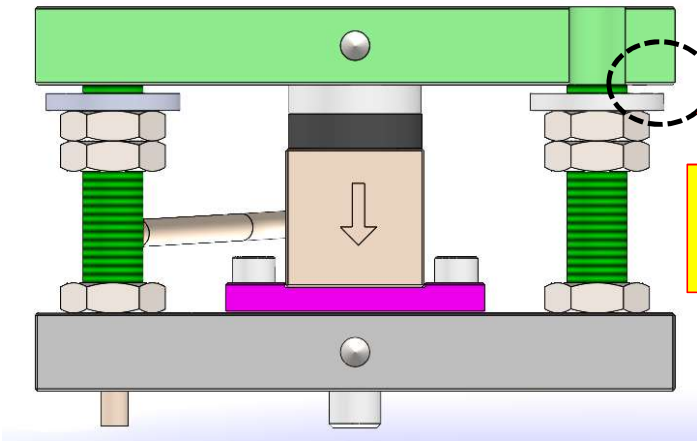

Kit with unlocked condition

PREPARED BY	CHECKED BY	APPROVED BY	PAGE NO	DOCUMENT NO
Refer digitally approved sign in page 21 of 21			17 of 21	IGP-001-TW R02

Load cell kit **inside** assy condition details – for understanding

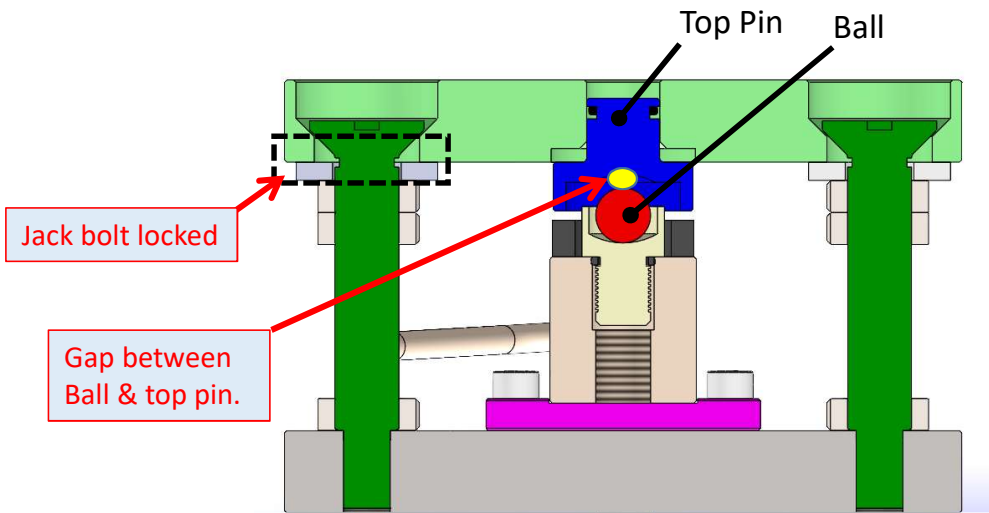

Kit with locked condition

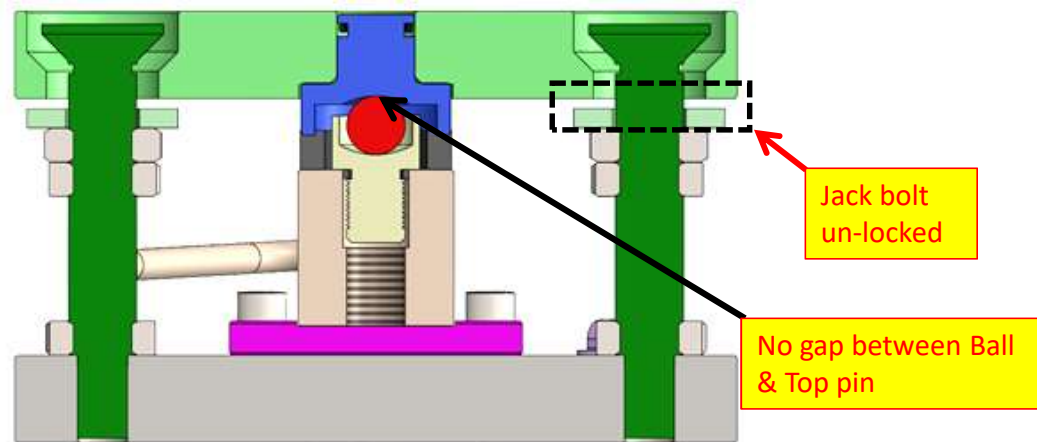

Kit with un-locked condition

PREPARED BY	CHECKED BY	APPROVED BY	PAGE NO	DOCUMENT NO
Refer digitally approved sign in page 21 of 21			18 of 21	IGP-001-TW R02

Procedure for installation of Load cell kit in existing Tanks or Silos

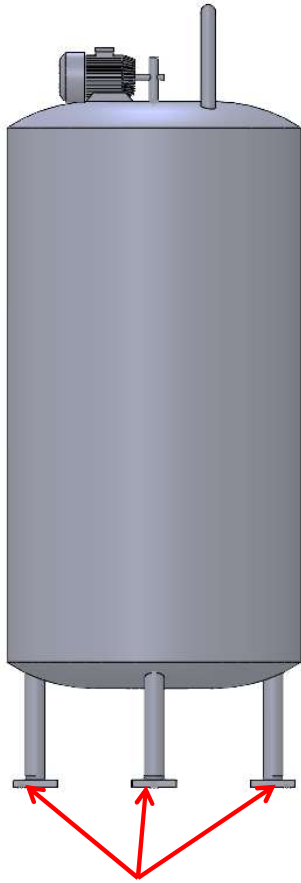

Existing plates of tank
to be modified

Procedue sequence :

1. Tank existing leg plates OR additional plates should be prepared to suit Top plate dimensions of **Essae** tank weighing kit.
(Refer schematic diagram of page 4)
2. Follow installation sequence from Steps 1 - 9

PREPARED BY	CHECKED BY	APPROVED BY	PAGE NO	DOCUMENT NO
Refer digitally approved sign in page 21 of 21			19 of 21	IGP-001-TW R02

Position of Anti-Vibration pads as Accessory

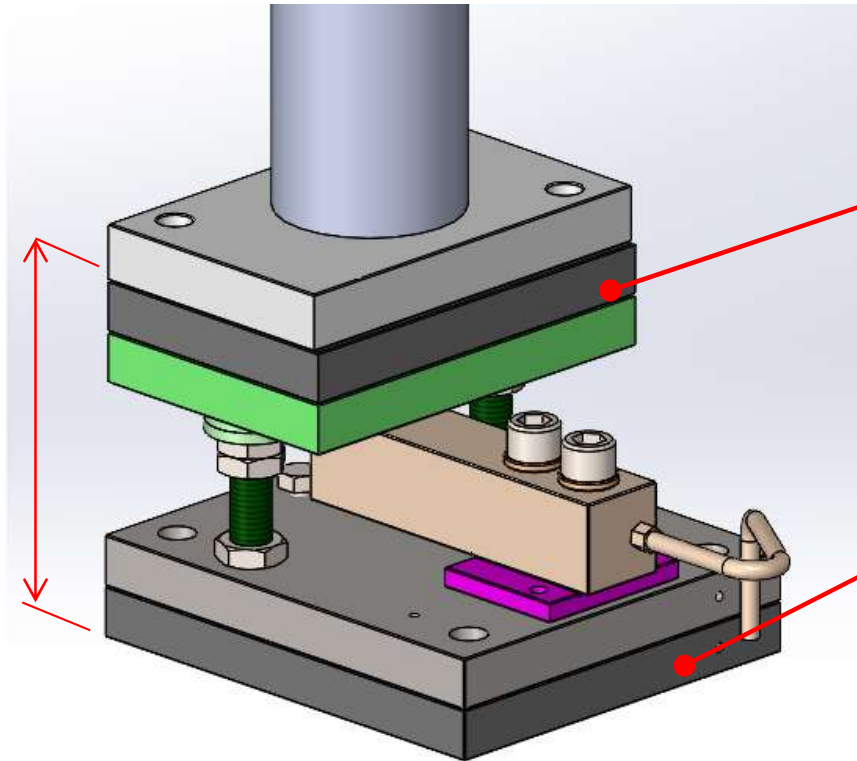

Anti-Vibration Pad
Between Tank leg
and Top plate







Anti-Vibration Pad
Below Bottom plate

Note:

With Anti-vibration pads,
total height of Kit
will increase by 30mm (apprx)

PREPARED BY	CHECKED BY	APPROVED BY	PAGE NO	DOCUMENT NO
Refer digitally approved sign in page 21 of 21			20 of 21	IGP-001-TW R02

Required Fasteners & Tools during installation

	Load cell kit Capacity	Hexagon Bolt - SS304		Spanner-A	Spanner-B	Allen key-A	Allen key-B	Spirit level bubble leveler	Water level tube
		Size	Qty (nos)						
Standard kit	Up to 3t	M12 x 35	6	19	22	4 mm	8mm		
	6t to 10t	M14 x 45	6	22	27	4 mm	14 mm		
With Anti-Vibration pad	Up to 3t	M12 x 45 *	6	19	22	4 mm	8mm		
	6t to 10t	M14 x 55 *	6	22	27	4 mm	14 mm		

* These marked bolts will be supplied along with Anti-vibration pads by Essae.

PREPARED BY	CHECKED BY	APPROVED BY	PAGE NO	DOCUMENT NO
KIRAN NL	Srinivasu.M	Srinivasu.M	21 of 21	IGP-001-TW R02